

Medo Brand Blowers for Aerobic Sewage Treatment Systems Installation Manual

Models : LA-60ECO

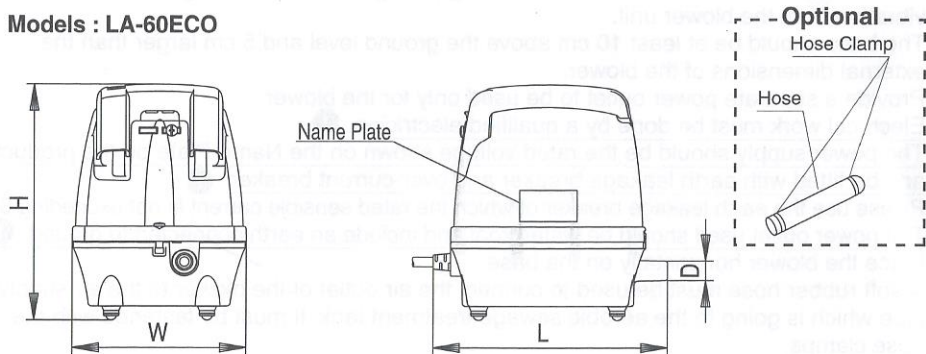

Models : LA-80ECO

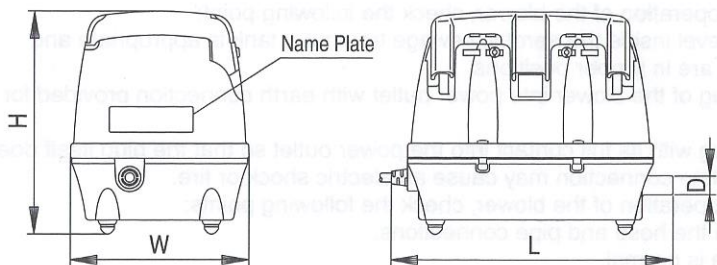

Attention

Attention : This installation manual should be read and understood thoroughly before any installation is executed.

After reading this installation manual, please keep it handy for reference.



Nitto Kohki Co., Ltd.
9-4, Nakaikegami 2-Chome, Ohta-Ku, Tokyo 146-8555, Japan
Tel: (03) 3755-1111 Fax: (03) 3753-8791

LQ07055-1

Specifications

Model	LA-60ECO	LA-80ECO
Rated Voltage : V AC	220/230/240*	
Rated Frequency : Hz	50	
Rated Pressure : kPa(kgf/cm ²)	14.7 (0.15)	
Operating Pressure Range : kPa(kgf/cm ²)	5 ~ 20 (0.05 ~ 0.2)	
Rated Airflow : L/min	60	80
Power Consumption : W	35	51
External Dimension(L×W×H) : mm	216(L)×160(W)×219(H)	270(L)×170(W)×215(H)
Outlet Outside Diameter(D) : mm	18	
Weight : kg	4.3	6.1

* This unit must be operate only at the voltage indicated on the Name Plate.

1. For Safe Operation

Various symbols are used in this manual and on the product itself which are aimed at proper and safe operation in order to prevent injury to yourself or others or damage to property. The meanings of these symbols are explained below. Please be sure you understand their meanings before you read this manual.

Explanation of Diagrammatic Expressions (terms and symbols)

The term "Attention" used in this manual is to alert you to dangers such as the following.

Term



Attention

Degree of Danger Indicated by The Term

This term indicates the possibility that continuing to work while ignoring this Attention, or working incorrectly without full understanding, may cause personal injury or physical damage.

The following symbols are used in this manual.

Symbol Meaning



This symbol advises you of an item which should be Noted (including Danger and Warning). The symbol on the left is the general note but specific details to be noted will be shown by a picture, word or explanatory text inside or near to the triangle.



This symbol advises you of an action which must not be taken (is prohibited) in order to avoid danger. The symbol on the left is a general prohibition but specific details of the action which must not be taken will be shown by a picture or explanatory text inside or near to the symbol.



This symbol advises you of an action which must be taken (is mandatory) in order to avoid danger. The symbol on the left is a general emphasis but specific details of the action which must be taken will be shown by a picture or explanatory text inside or near to the symbol.

2. Safety and Operating Instructions

The following safety precautions should always be followed to reduce the risk of breakdown and/or accident;

Attention : Prevent Electric Shock and Fire



Attention

- (1) Don't install the blower where will be inundated with water.
- (2) Electrical work must be done by a qualified electrician.
- (3) The power supply should be the rated voltage shown on the Name Plate on the product and be fitted with earth leakage breaker and over-current breaker.
- (4) The power outlet used should be waterproof and include an earth connected to ground.
- (5) If the supply cord is damaged, it must be replaced by the manufacturer or its service agent or a similarly qualified person in order to avoid a hazard. Ignoring any of above may cause an electric shock or fire.

- Check if the voltage and frequency on the Name Plate is suitable for the supply voltage and frequency.
- If the body, its cable, or plug is found to be damaged on receipt, do not use but contact the seller.
- Install the blower higher than the water level, which will prevent water siphoning when the blower is turned off.
- Clean the filter located on the top of the product approximately every 3 months. In dusty environment, more frequent cleaning will be necessary.

Maintenance of Filter

- ① Be sure to pull out the power supply plug from the power outlet.
- ② Loosen the screw, and open the filter cover.
- ③ Remove the filter from the upper case.
- ④ Clean the filter or replace it with a new filter.
- ⑤ Install the filter in the upper case.
- ⑥ Close the filter cover and tighten the screw.

- This product is not intended for use by persons (including children) with reduced physical, sensory or mental capabilities, or lack of experience and knowledge, unless they have been given supervision or instruction concerning use of the appliance by a person responsible for their safety.
- Children should be supervised to ensure that they do not play with the product.

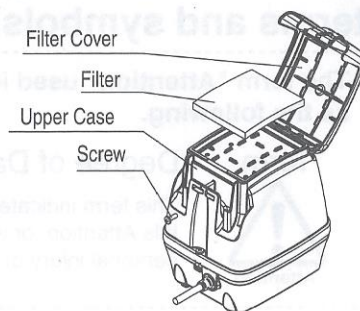

3. Installation

- (1) Check the contents of the package.

Main Unit : Blower ... 1 Installation Manual ... 1
 Optional : Hose ... 1, Hose Clamp ... 2

- (2) Installation site selection

Install near the aerobic sewage treatment tank.

If the air line is long, the aerobic sewage treatment system may not be able to perform due to an insufficient airflow.

Install in a place which is convenient for maintenance.

Don't install over a manhole or on soft ground.

Consider ventilation in choosing the installation site for the blower.

- Install at least 30 cm away from a building.
- Select a site as cool as possible.
- Don't cover up the blower and avoid badly ventilated areas.
- Avoid areas where wind-blown leaves and dusts gather.

Consider humidity in choosing the installation site for the blower.

• Don't install the blower where will be inundated with water. ⚡

• Don't install where there is excess moisture or humidity.

Consider noise in choosing the installation site for the blower.

• Avoid installing near bedroom or study windows.

It may be a nuisance since the blower runs day and night.

- (3) Method of Installation

Recommend a concrete base.

• The base should be made of concrete strong enough to bear the weight and block vibration from the blower unit.

• The base should be at least 10 cm above the ground level and 5 cm larger than the external dimensions of the blower.

Provide a separate power outlet to be used only for the blower.

• Electrical work must be done by a qualified electrician. ⚡

• The power supply should be the rated voltage shown on the Name Plate on the product and be fitted with earth leakage breaker and over-current breaker. ⚡

• Please use the earth leakage breaker of which the rated sensible current is not exceeding 30mA.

• The power outlet used should be waterproof and include an earth connected to ground. ⚡

Place the blower horizontally on the base.

A soft rubber hose must be used to connect the air outlet of the blower to the air supply pipe which is going to the aerobic sewage treatment tank. It must be fastened with the hose clamps.

• When making the connection, adjust the heights of the air outlet on the blower and the air intake on the aerobic sewage treatment tank to ensure the hose is not kinked or blocked.

Before starting the operation of the blower, check the following point:

• Check if the water level inside the aerobic sewage treatment tank is appropriate and the valves on pipes are in proper positions.

Insert the power plug of the blower into power outlet with earth connection provided for its exclusive use.

• Insert the power plug with its full contact into the power outlet so that the plug itself does not wobble. Incomplete connection may cause an electric shock or fire.

Before starting the operation of the blower, check the following points:

• No air leakage from the hose and pipe connections.

• The operating noise is normal.

• The vibration is not transmitted to the aerobic sewage treatment tank due to strained piping.

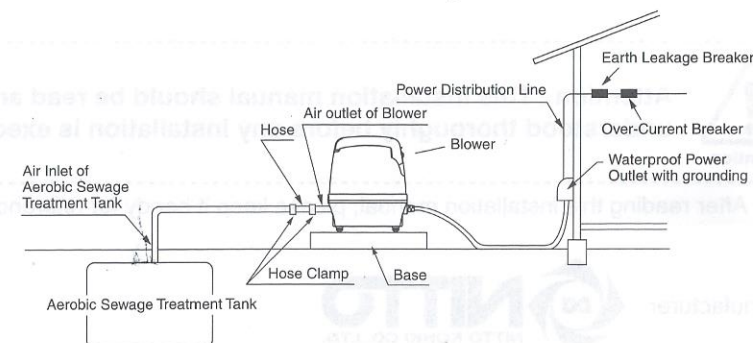

- (4) Caution for Operation

Long time operation under high pressure outside the designated pressure range will shorten the Blower life.