

UV FILTRATION PUMP

CUP-803/805/807/809

Instruction



Before operating this appliance, please read this instruction manual completely and keep it handy for future reference!

【 PROLEGOMENA 】

Before the first time use, please read this instruction and acquaint this equipment. In order to use the equipment safely, the following secure suggestions should be abided.

【 CAUTION 】

CUP-8 is UV clarifier equipment which can be fixed. It contains water pump and one piece of UV lamp. Any damage on the equipment or unmerited operation will bring dangerous radiation to the skin and eyes. So if there is any damage of the equipment, it can not be used any more. This equipment is not intend for use by persons (including children) with reduced physical, sensory or mental capabilities, or lack of experience and knowledge, unless they have been given supervision or instruction concerning use of the equipment by a person responsible for their safety. The equipment should be placed out of children reach. For the consideration of security, people younger than 16 years old and those who can not identify danger or grasp the instruction can not use the equipment.

1. This equipment should be placed under the water. Be sure the equipment is submerged completely in the water and the deepness should not bigger than 2m.

2. Before the water submerge the equipment, please never plug in to avoid the equipment working without water which will bring damage to the equipment.

3. Please make sure that the electrical voltage, frequency used are consistent with the indication on the label of the equipment.

4. The equipment is a kind of fixed appliance with rubber feet under it which can help the equipment to fix on the slippery surface (such as glass and so on); Because the UV lamp is made of quartz glass, please avoid drop of it or wallop on it. The detailed information about installation, please check the instruction information.

5. If there is any damage on the power cable, UV lamp or shell, the equipment can not be used. And it should be discarded as useless.

6. Pull the connecting cable is forbidden. And please keep the connecting cable away from heat, greasiness or sharpness.

7. When installing the equipment, the installation regulation of domestic should be followed.

8. In order to ensure the effect of the equipment, the UV light tube should be replaced after 8000 hours' usage.

9. When the body shell is blocked with the sands and rubbish, it is possible to destroy the quartz tube. So please add the filter sponge in the inlet of the water. And the sponge should be cleaned in time (one month one time).

10. When install or repair this equipment, the electrical source of the aquarium must be switched off.

11. UVC is harmful to the eyes and skin. Please do not watch UVC directly or let the skin approach to the UVC.

【 FEATURES 】

1. This product rolled filter fountain sterilization oxygen pumping and many other functions into one, compact configuration cabinet bulk.

2. Turn on and off the UV-C clarifying through the separate switch.

3. With high quality sponge and active carbon.

4. Fit for big aquariums.

【 INSTRUCTION 】

1. This equipment can kill the harmful germ and algae in the aquarium and the pond which offer the healthy environment to the fishes.
2. When the water under the irradiation of wavelength in 253.7nm ultraviolet radiation in a short period, the germ and pathogen in the water will be killed then.
3. This equipment is matched with water pump. So it is no need to buy water pump separately.
4. This series of equipment can be fixed on the glass of aquarium. You can also use screw to replace the rubber feet in order to fix it on other object(the weight of them should be more than 18kgs).
5. Plug in the equipment. The water pump and UV lamp start work.
6. The detailed sketch map of usage can be found in the packing box.

【 EQUIPMENT STRUCTURE 】

Before the installation and use, please get to know the structure of products. It contributes to using products correctly, proper maintenance and prolonging product life. The detailed structure is illustrated below:

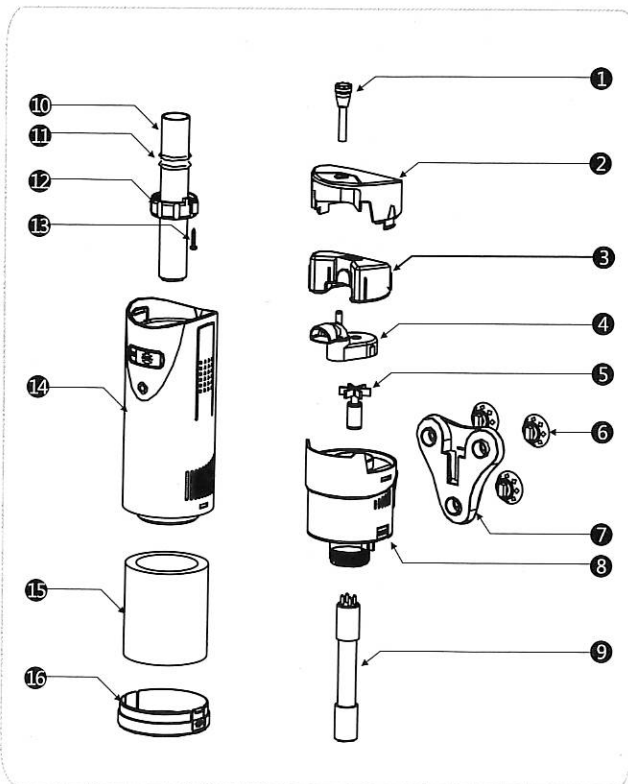

| | |
|----|---------------|
| 1 | Oxygen Valve |
| 2 | Top Cover |
| 3 | Active Carbon |
| 4 | Impeller |
| 5 | Rotor |
| 6 | Suction Cups |
| 7 | Base |
| 8 | Motor Part |
| 9 | UV Bulb |
| 10 | Quartz Tube |
| 11 | O-Ring |
| 12 | Screw Nut |
| 13 | Set Screws |
| 14 | Filter Casing |
| 15 | Sponge |
| 16 | Back Cover |

【 APPLICABILITY & TECHNICAL PARAMETER 】

| MODEL | VOLTAGE | POWER | POWER OF UV LAMP |
|---------|-----------|-------|------------------|
| CUP-803 | 230V/50Hz | 14W | 3W |
| CUP-805 | 230V/50Hz | 16W | 5W |
| CUP-807 | 230V/50Hz | 18W | 7W |
| CUP-809 | 230V/50Hz | 20W | 9W |

【 MAINTENANCE 】

Before clean the equipment or replace the UV lamp, please make sure the electricity has been cut off.

This series of equipment should be maintained or replaced the UV lamp after used for a period. Please check the structure picture to do as follows.

1. Press the button on the both side of the filter basket to pull out the back cover(16) and sponge(15), clean the sponge.
2. Pull out the filter basket(14), clean the rubbish on the quartz tube via brush.
3. Using the screwdriver to move away the screws(13), pull out the quartz tube to change the UV bulb.
4. Pull out the oxygen valve(1), press two side of top cover to pull out the top cover, take out the active carbon, then clean it.
5. Take out the impeller and shaft, clean it via brush.
6. Install it after cleaning.

Because this equipment' s power cable adopt the "Z" model ,please discarded as useless when the power cable is broken.

Meaning of crossed-out wheeled dustbin. Do not dispose of electrical appliances as unsorted municipal waste, use separate collection facilities. Contact you local government for information regarding the collection systems available. If electrical appliances are disposed of in landfills or dumps, hazardous substances can leak into the groundwater and get into the food chain, damaging your health and well-being. When replacing old appliances with new ones, the retailer is legally obligated to take back your old appliance for disposals at least free of charge.

WARRANTY CARD (leaf For Retailer)

| | | | |
|-----------|-------|------------------|--|
| Model No. | | Date of purchase | |
| User | | Address | |
| Zipcode | Phone | Contact person | |
| Retailer | | | |